

SKS
WELDING SYSTEMS

WELD PACKAGE
**POWER
JOINT**

The **Weld Package** for your Welding Tasks
from the Power Source to the Contact Tip

AIR-COOLED



CONTENT

Power Source • Weld Process
Controller • Software •
Interface • Wire Feeder Unit •
Wire Guidance •
Cable Bundle • Control Cable •
Torch System • Torch Necks •
Consumables

WELDING PROCESSES

GMAW
KF-pulse
Pulse
MIG-Brazing



STEEL

SKS Weld Package: System design

The Power Joint Weld Package contains:

- A Integrated solution: power source, weld process controller and interface in one device
- 1 Power Source
- 2 Weld Process Controller and Software/IT
- 3 Robot Interface
- 4 Wire Feeder
- 5 Wire Guidance
- 6 Ground Cable
- 7 Control Cable
- 8 Cable Bundle
- 9 Torch System Power Joint
- 10 Torch Neck/Consumables
- 11 Reamer Blades
- 12 TCP Dimensions/Checking Fixtures/Torch Cleaning Stations



For installations with inner cable dress.

This brochure contains information about the SKS Weld Package, the torch system Power Joint, as well as consumables and spare parts. There are various features of the welding machine components and torch systems available depending on the robot system and the welding task. The **Power Joint Weld Package** can be used with all common industrial robots.

A



Components 1, 2 & 3
also available as an integrated
solution – LSQ COMPACT.



Power Joint – air-cooled for steel applications

Processes:	GMAW, KF-pulse, Pulse, MIG-Brazing
Wire materials:	high-alloy steels, low-alloy steels
Compatibility:	for all common industrial robots
Weight:	2.3 kg
Max. power:	420 A – 60 % duty cycle/40 °C, air-cooled
Wire diameter:	0.8-1.6 mm
TCP accuracy:	± 0.2 (400 mm)

A Integrated Solution LSQ COMPACT

LSQ COMPACT



The LSQ COMPACT IoT was designed as an integrated welding system, combining the weld process controller, Fieldbus interface, and power supply into one unit, resulting in a compact size with fewer external connections – for easy installation. Even with its compact size and integrated design, this machine is powerful and incorporates 35 years of technological knowledge. Whether you are welding thick aluminum plates or thin stainless steel, a process is available to support your specific needs. All processes are unlocked and readily available. You do not need an additional license or passcode to use them.

Up Front Pricing:

**No hidden costs for
welding processes
and software functions.**

A Integrated Solution LSQ COMPACT

Compact: All in One, All Inclusive. Compatible with SKS Weld Packages: Power Clutch, Power Joint and Frontpull.



POWER SOURCE
+ PROCESS CONTROLLER
+ ROBOT INTERFACE

420 A
60% DUTY CYCLE
AT 40°C

**READY FOR
GLOBAL USE**
CE, UL & CCC
CERTIFIED

**MQTT
OPC UA****
+ TRACEABILITY

MATERIALS:
steel
low- & high-alloy steel
copper alloys
galvanized steel
aluminum*

**INCLUDES THE
WELDING PROCESSES
AND FUNCTIONS:**
GMAW
I-pulse
KF-pulse
microMIG*
microMIG-cc*
MMT-x*
DP-Fast
MIG-Brazing
Synchroweld
AutoComp

**Q8
TOOL**
**FREE WELD DATA
DOCUMENTATION
& MANAGEMENT**

* Only in combination with Frontpull torch system. Further information can be found in the Frontpull Weld Package
** Only available in LSQ COMPACT IoT

A Integrated Solution LSQ COMPACT



LSQ3 COMPACT Lite



LSQ5 COMPACT IoT

Integrated power source

The LSQ COMPACT Lite and IoT are available with LSQ 3 and LSQ 5 power sources to provide the best solution for your application. The technical data can be found on the following pages.

Integrated weld process controller

While the LSQ COMPACT Lite is designed for maximum cost efficiency, the LSQ COMPACT IoT offers additional features such as the Internet of Things (IoT), MQTT, and OPC UA support. This advanced weld process controller enables extended real-time monitoring and analysis of welding processes, resulting in improved quality assurance and more precise control of the process.

Specifications	Lite	IoT
Operation via	buttons	touch screen
Programs	15.872	15.872
Ports	USB, SD card slot	Ethernet, SD card slot
MQTT / OPC UA	No	Yes
Remote Control	Q8Tool	Q8Tool, VNC client

Integrated interface

With the included Fieldbus Interface FB5 the system can be perfectly integrated into existing Fieldbus environments. Various Fieldbus types are available e.g. EtherNet/IP, Profinet CU.

Overview LSQ COMPACT	Part-No.
LSQ5 COMPACT Lite	77-1185-71x
LSQ3 COMPACT Lite	77-1184-78x
LSQ5 COMPACT IoT	77-1185-77x
LSQ3 COMPACT IoT	77-1184-81x
LSQ5 CCC COMPACT Lite	77-1185-73x
LSQ3 CCC COMPACT Lite	77-1184-73x
LSQ5 CCC COMPACT IoT	77-1185-79x
LSQ3 CCC COMPACT IoT	77-1184-79x

Please note:

Various field bus types available. Please enter the number you require in place of the x:
1 = EtherNet/IP | 2 = Profinet CU | 3 = EtherCAT



Accessories: Wall mount for LSQ5
Space-saving design that makes for easy cleaning/maintenance.

Wall mount

Overview of wall mounts	Part-No.
Wall mount for power source LSQ5 and LSQ5 COMPACT	77-1180-01
Wall mount for power source LSQ3 and LSQ3 COMPACT	integrated

1 Power source



LSQ5 power source

LSQ5 power source with Direct Control Technology (DCT)

The LSQ5 ensures the optimum arc energy. It uniquely adjusts to different weld processes. Unlike conventional power sources with inverter technology, the LSQ5 with Direct Control Technology controls its switching transistors without any fixed clock frequency according to the needs of the weld process. Without any delay, the energy needed for the process is provided instantly. The flexible fine tuning is done by a central processor. The CPU continuously analyzes the weld process and current/voltage values on the basis of data obtained and optimally drives the switching transistors of the power section. This results in an extremely high efficiency and a low temperature development.

The power source can be configured with only two buttons and four LED indicators. For worldwide usage, voltages can be configured without opening the power source.



LSQ3 power source

LSQ3 power source with Direct Control Technology (DCT)

The LSQ3 offers enough power reserves for special weld tasks like chassis and exhaust parts and other thin sheet metal applications.

Overview of power sources	Part-No.
DCT power source LSQ5 Direct-Control-Technology	77-1185-00
DCT power source LSQ3 Direct-Control-Technology	77-1184-50
DCT power source LSQ5-CCC Direct-Control-Technology	77-1185-60
DCT power source LSQ3-CCC Direct-Control-Technology	77-1184-40

The main benefits are:

- DCT provides a speed regulation up to ten times higher compared to conventional inverter technology. This leads to excellent control behavior and shorter response times.
- The weld properties are substantially improved. Software replaces hardware: Fewer components also increase the reliability in continuous operation.

Specifications	LSQ5 (-CCC)	LSQ3 (-CCC)
Performance	420 A - 60% duty cycle/40 °C (400 A)	340 A - 60% duty cycle/40 °C
Processes and functions	GMAW, I-pulse, KF-pulse, microMIG*, microMIG-cc*, MMT-x*, DP-Fast, MIG-Brazing, Synchronweld, AutoComp	
Weight	49 kg	37 kg
Primary voltage	3 x 400 (480)V	
Wall mounting	Yes (optional)	Yes (integrated)
Conformities	CE, CSA, UL (CCC)	CE (CCC)
Dimensions	450 x 400 x 540 mm	450 x 330 x 540 mm

* Only in combination with Frontpull torch system. Further information can be found in the Frontpull Weld Package.

2 Weld process controller

Innovative Control Concepts with Touch Screen.

With the new Q84r and the compact Q84s up to four weld machines can be controlled centrally.

- **Parameter settings** completely integrated in the SKS software
- **Documentation** of measurements + TCP speed

- ✓ All settings on a single screen
- ✓ All measurements on a single screen
- ✓ All SKS welding processes and functions available
- ✓ Ready to use Industry 4.0 protocols (MQTT + OPC UA) and data traceability!

Q8
TOOL



2 Weld process controller

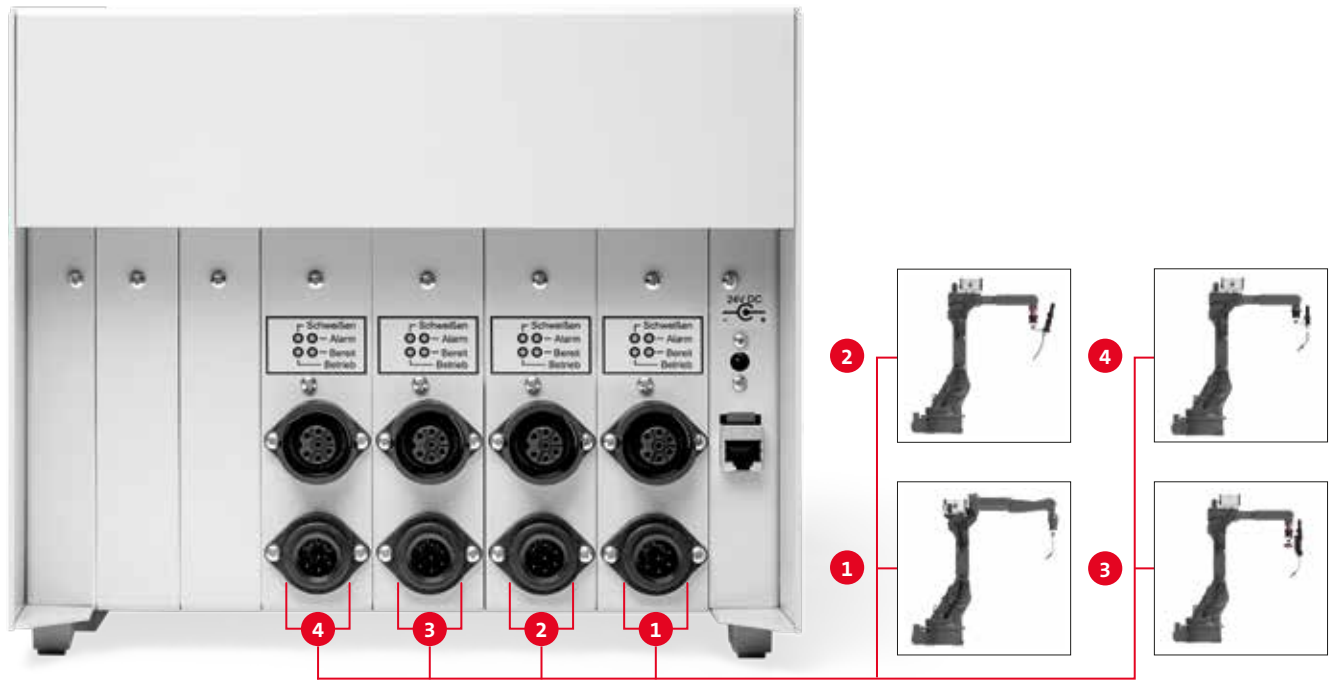

Controlling up to four weld machines at the same time

The new Q84r and Q84s are equipped with a touch screen, an innovative usability concept and an advanced visualization technology for much easier operating. The user interfaces have the look and feel of the Q8Tool4 software. Individual weld process controllers are in card slots in the Q84r/s. This new weld process controller concept can host up to four weld process controller cards. Each card independently controls a weld machine. As an alternative to the Q84r/s weld process controllers, the Q80 has been developed to control a single weld machine.

2 Weld process controller



Q84r weld process controller



Q84r Weld process controller

Please note:

The Q84r/s can be equipped with up to four weld process controller cards.

Weld process controller Q84r/s

The universal weld process controllers Q84r and Q84s calculate the optimal parameters for each welding process. Only basic data such as material, wire type, wire feed speed and type of gas must be entered. The Q84r is equipped with a 10" touch screen, the space-saving Q84s with a 7" touch screen. For wall mounting the display of the Q84s can be rotated by an angle of 180°.

- Processes and functions: GMAW, I-pulse, KF-pulse, microMIG*, microMIG-cc*, MMT-x*, DP-Fast, MIG Brazing, Synchronweld, AutoComp
- Programs: 15.872 (x4)
- General functions: Display and saving of readings, alarms
- Monitoring functions: Weld current monitoring, auto compensation, arc and ignition monitoring, motor current, gas and water monitoring
- Easy to network via Ethernet: Traceability
- Ports: RJ45-Ethernet, SPW-Bus, SD card slot
- Remote Control/Administration: Q8Tool, VNC client
- Supports MQTT / OPC UA

Overview weld process controllers	Part-No.(Q84s)	Part-No. (Q84r)
Q84s/r weld process controller with one weld card	77-7410-001	77-7310-001
Q84s/r weld process controller with two weld cards	77-7420-001	77-7320-001
Q84s/r weld process controller with three weld cards	77-7430-001	77-7330-001
Q84s/r weld process controller with four weld cards	77-7440-001	77-7340-001

Overview Q84r/s mounting kits	Part-No.
Bracket for Q84r for mounting onto power source LSQ3/5	77-7240-01
Mounting brackets for Q80/Q84s for mounting onto power source LSQ3/5	77-7240-06
Bracket for Q84r for wall mounting	77-7240-02
Bracket for Q84r mounting in the robot cabinet	77-7240-05

Overview Q84r/s accessories	Part-No.
Connection cable for Q84r/s 5m with open end (optional)	77-3305-00
Plug for external power supply of Q84r/s	77-7240-96
USB adapter for SD/microSD cards	91-8-1

Overview Q84r/s replacement parts	Part-No.
Touchpen for Q80 / Q84r/s weld process controller (spare part)	77-7240-03
SDHC card 8GB for Q84r/Q84s/Q80 weld process controllers	91-8-6

* Only in combination with Frontpull torch system. Further information can be found in the Frontpull Weld Package.

2 Weld process controller



Q80 weld process controller – front view



Q80 weld process controller – back view

Weld process controller Q80

The Q80 is the alternative to the Q84r/s. It has the same functionality/features as a single weld card of the Q84r/s - optimized for a single weld machine. With the universal Q80 all parameters and values needed for the weld task can be optimally calculated

- Processes/functions/general functions see Q84r/s
- Easy to network via Ethernet: up to traceability
- Ports: RJ45-Ethernet, SPW-Bus, SD card slot
- Wall mounting capability
- Remote Control / Administration: Q8Tool
- Supports MQTT / OPC UA

Overview weld process controller	Part-No.
Q80 weld process controller	77-7260-001

Overview Q80 mounting kits	Part-No.
Bracket for mounting onto power source LSQ5	77-7240-06

Overview Q80 accessories	Part-No.
USB adapter for SD-/microSD card	91-8-1

Overview Q80 replacement parts	Part-No.
Touchpen for Q80 / Q84r/s weld process controller (replacement part)	77-7240-03
SDHC card 8GB for Q84r/Q84s/Q80 weld process controllers	91-8-6

2 Software/IT

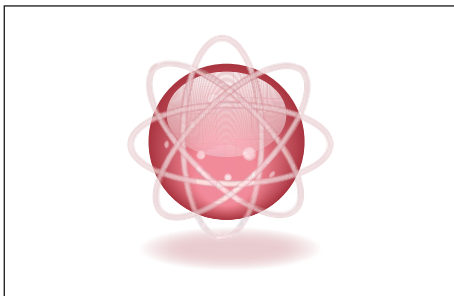

Q8Tool software

The Q8Tool software provides accurate and comprehensive process monitoring. The user can store weld parameters for documentation on a PC and/or administrate them. It offers basic functions such as reading, modifying and documenting of weld parameters. Additionally, new weld parameters can be created and transferred to the universal weld process controllers. The weld data is portable and the installation of further control units on new equipment is easy. Also, the software allows reading and exporting of measurements and alarms. Graphical and numerical recording of measures helps defining and optimizing parameters for new parts. Users have a powerful tool for analyzing and documenting their weld results.

Network

The weld process controller units can easily be networked via Ethernet ports: Time savings through centralized administration of all controllers within the corporate network. There is a central backup of all welding parameters, management of user rights and access, process monitoring up to traceability. The Q8Tool software is provided free of charge with the weld process controller. No additional hardware or software is required.

3 Robot interface

Perfect integration.

Interfacing all industrial robot types.



By the use of Fieldbus Interface FB5 the system can be perfectly integrated into existing Fieldbus environments. For analog and digital environments the universal interface UNI5 is available on request.

Standard application

Fieldbus systems exchange signals via serial communication. The Fieldbus master, usually the robot controller or overall system controller, bundles and processes the signals of the connected Fieldbus, including the welding machine. Standard Fieldbus systems are e.g., Interbus-S, Profibus DP or DeviceNet.

The Fieldbus interface FB5 translates the Fieldbus signals for the welding machine using a standardized protocol. It makes no difference which type of Fieldbus system is used. The signals are always at the same place on the Fieldbus. This makes the preparation of the robot or system controller much easier.

3 Robot interface



FB5 Fieldbus Interface: mounting onto the power source



FB5 Fieldbus Interface: mounting onto the cabinet

Fieldbus application

Various Fieldbus types are supported (e.g. Profibus DP, DeviceNet). The Fieldbus interface has drilled bore holes for flexible mounting within the weld cell. Two additional mounting kits provide easy installation at the power source or into the cabinet. Additionally, external power can be connected to the interface. More details on solutions for the specific Fieldbus types are available on request.

Overview FB5 interfaces	Part-No.
Fieldbus interface FB5 Interbus-S (copper line)	77-3-1
Fieldbus interface FB5 Profibus DP	77-3-2
Fieldbus interface FB5 DeviceNet	77-3-3
Fieldbus interface FB5 EtherCAT	77-3-4
Fieldbus interface FB5 Profinet IRT (copper line)	77-3-5
Fieldbus interface FB5 Profinet IRT (LWL 2 Port)	77-3-6
Fieldbus interface FB5 Interbus-S (LWL FSMA)	77-3-7
Fieldbus interface FB5 Ethernet/IP	77-3-8

Cabinet mounting	Part-No.
Mounting kit for cabinet	77-1182-02
Cabinet cable 2m FB5 with device plug and cable socket	77-3102-02

Power source mounting	Part-No.
Bracket for FB5/Q6pw for mounting onto LSQ3/5	77-1182-03

Optional power supply (24V)	Part-No.
Connection cable 2.0 m (with open end)	77-1182-04

SYNCHROWELD

Synchroweld unites the weld system and robot by a communication protocol (RWDE). This technology allows the weld system to get the actual robot speed and automatically adjusts the weld parameters and laser power within defined limits. The result is a constant energy per unit length. At the same time, the programming effort can be significantly reduced.

Please note:

Further information on Synchroweld with ABB, Fanuc, KUKA, Yaskawa can be found in our Synchroweld brochure.

4 Wire Feeder

Strong, lightweight and precise.

The PF6 wire feeder.

Smaller and with less weight accompanied by improved efficiency over conventional wire feeders the PF6 goes along with the steady development of arc welding robots.



Power Feeder PF6

The industrially proven wire feeder PF6 has been enhanced with an additional control and monitoring function - an integrated gas regulation system in addition to the gas flow sensor. The ability to regulate gas flow for the actual weld seam is a crucial factor for seam quality. This also leads to cost savings, as only the amount of gas currently required is passed through the torch system. The proven gas flow sensor, used to monitor the flow rate, is also implemented in this wire feeder variant. Especially with complex components, not having the required gas flow rate can result in high costs, as the component may become unusable - in the best case, it can only be salvaged through extensive rework. The target and actual gas quantities can be read on the welding process control system. Additionally, an alarm can be triggered if the values fall below or exceed the set limits.

Overview PF6	Part-No.
PF6 wire feeder	10-3-9
PF6 wire feeder with integrated gas regulation	10-3-509
Specifications	
Weight	4.1 kg
Motor	70 W
Wire feeding speed [v]	2.5 - 25 m/min
Drive roll for wire diameter	0.8 - 1.6 mm

Center guide

The center guide ensures a defined routing of the welding wire within the four roll drive.

Overview center guide	Part-No.
Center guide for PF5/6 wire feeder, wire-ø 0.8 - 1.6 mm for steel wire	12-2-1-15



4 Wire Feeder



Please note:

Two drive rolls per system are needed.

Please note:

Drive rolls for wires in inch sizes available on request.

Drive roll

Our drive rolls are available in several groove shapes for different welding filler materials (V-groove for steel and knurled U-groove for filler wire applications).

Overview drive rolls	Part-No.
Wire- \varnothing 0.8 mm, V-groove	12-2-3-08
Wire- \varnothing 0.9 mm, V-groove	12-2-3-09
Wire- \varnothing 1.0 mm, V-groove	12-2-3-10
Wire- \varnothing 1.2 mm, V-groove	12-2-3-12
Wire- \varnothing 1.4 mm, V-groove	12-2-3-14
Wire- \varnothing 1.6 mm, V-groove	12-2-3-16

Overview drive rolls	Part-No.
Filler Wire- \varnothing 1.0 mm, U-groove	12-2-3-310
Filler Wire- \varnothing 1.2 mm, U-groove	12-2-3-312
Filler Wire- \varnothing 1.6 mm, U-groove	12-2-3-316



Please note:

Two pressure rolls and two locating bolts are needed per system.

Pressure roll

The pressure roll ensures a defined pressure of the welding wire into the specific groove shape of the drive roll.

Overview pressure rolls	Part-No.
Pressure roll – DIN 625 T1 for PF5/6 wire feeder series	12-2-3-0
Locating bolt for pressure roll on two/four roller drive	12-13-5



Please note:

Wire feeder brackets for further robot types are available on request.

Wire feeder bracket

Wire feeder bracket with holes and mounting material for quick and easy installation.

Overview wire feeder brackets	Part-No.
For robot type-ABB (single wire)	
IRB 1600iD-4/1.5 / IRB 1660iD-6/1.55	14-12-5
IRB 2600iD-15/1.85 / IRB 2600iD-8/2.00	14-12-10
For robot type-FANUC (single wire)	
AM 100iD / AM 120iD / M-10iD/8L / M-20iD/12L	14-14-9

For robot type-KUKA (single wire)	
KR 6 R1840-2 HW / KR 8 R1440-2 HW / KR 8 R1640-2 HW	14-13-8
KR 8 R2100-2 HW	14-13-9
For robot type-YASKAWA (single wire)	
AR1440 / AR2010 / GP12 / GP25-12	14-11-30

5 FlexiGlide wire guidance

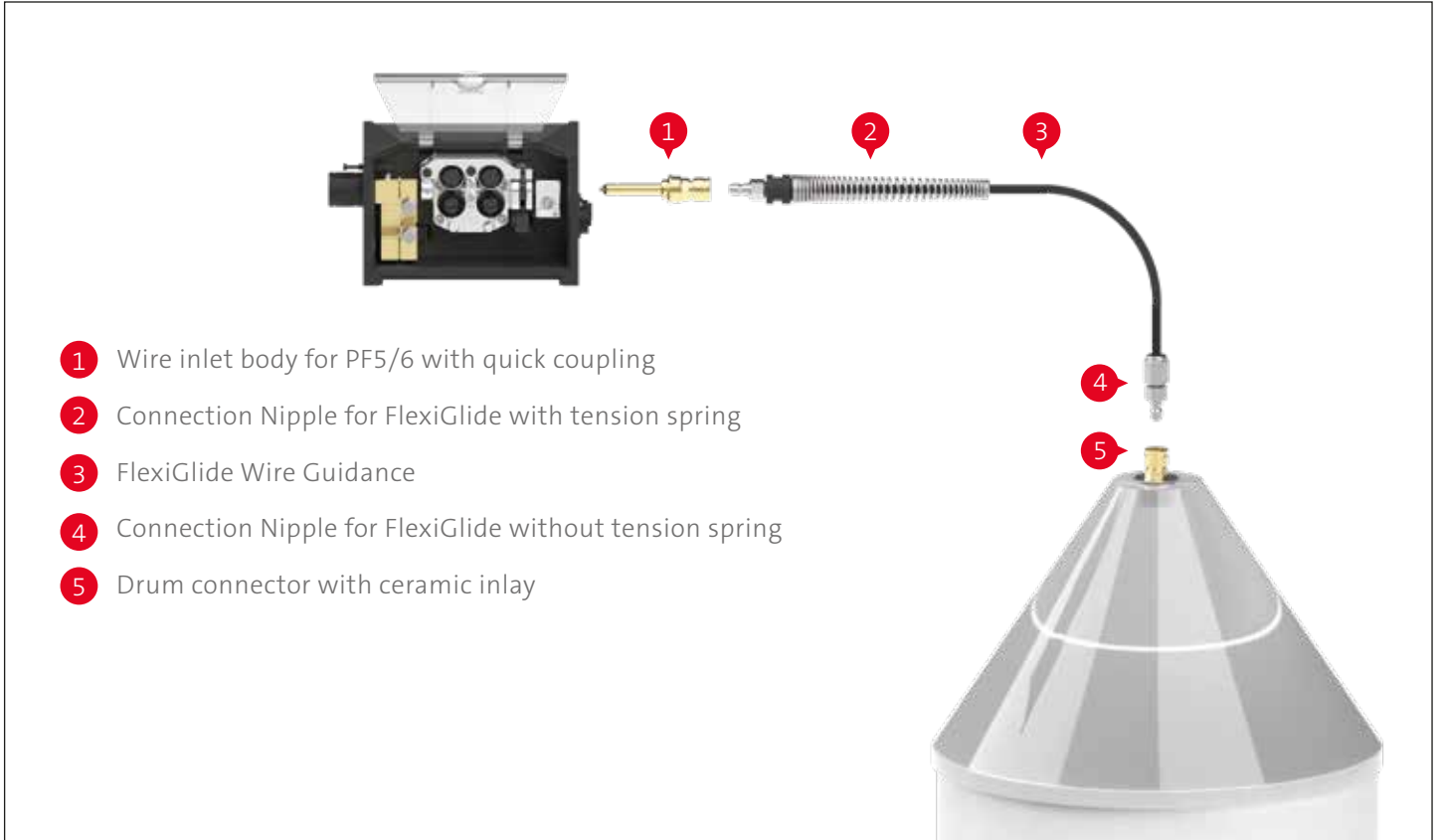

- 1 Wire inlet body for PF5/6 with quick coupling
- 2 Connection Nipple for FlexiGlide with tension spring
- 3 FlexiGlide Wire Guidance
- 4 Connection Nipple for FlexiGlide without tension spring
- 5 Drum connector with ceramic inlay

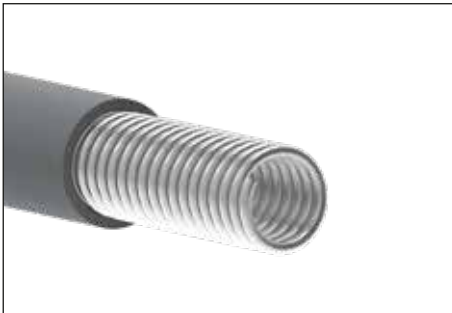

FlexiGlide Wire Guidance

Please note:

Further information can be found in our brochures "FlexiGlide" (PIN-0168) and "Wire guidance" (DOC-0193).

SKS Wire guidance FlexiGlide with a high limit of elasticity and very low friction. The constructive design, a coil made from chrome/nickel spring steel with a plastic coating, creates robustness, resulting in a high lifetime.

Benefits with FlexiGlide:

- Optimized for use in robotic applications
- High lifetime
- Very low friction
- Flame retardant and abrasion resistant

FlexiGlide wire guidance

Overview of FlexiGlide wire guidance	Part-No.
Wire Inlet Body for PF5/6 with Quick-Connector	10-2-0-61
Connection Nipple insulated for FlexiGlide with tension spring	44-3-11
FlexiGlide wire guidance, Type B, per meter	44-3-1
Connection Nipple for FlexiGlide without tension spring	44-3-4
Drum Connector with ceramic inlet	44-40-1

Option

Overview strain-relief on wire guidance	Part-No.
Strain-relief for wire guidance on wire feeder bracket	14-10-6
Through-Wall Mount for wire guidance FlexiGlide incl. suspension	44-3-8
Wall Duct for FlexiGlide wire guidance	44-3-9

5 Rolliner 3G wire guidance

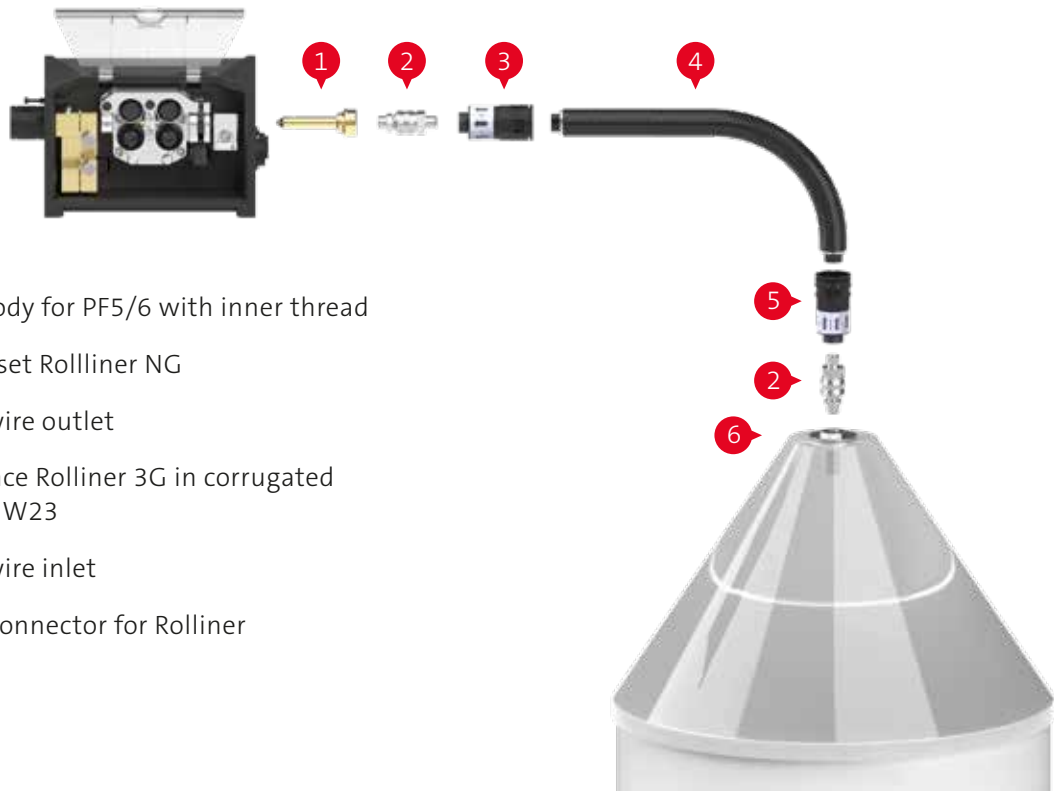

- 1 Wire inlet body for PF5/6 with inner thread
- 2 Connection set Rolliner NG
- 3 Connector wire outlet
- 4 Wire Guidance Rolliner 3G in corrugated tube black NW23
- 5 Connector wire inlet
- 6 Wire drum connector for Rolliner

Rolliner 3G Wire guidance is suitable for all applications where higher wire feeding requirements are needed.

Benefits:

- Optimized sliding properties with roller-supported wire guidance
- High flexibility due to segmentation of roller parts
- Suitable for use in harsh environments
- Universally application (steel, stainless steel, filler wire, aluminum)

Overview of Rolliner 3G wire guidance	Part-No.
Wire inlet body for PF5/6 with 1/4" NPTF inner thread	10-2-0-60
Connection set Rolliner NG for drum or wire feeder	44-60-21
Connector wire outlet for Rolliner 3G	44-60-42
Mounting clip for Rolliner 3G	44-60-45
Wire Guidance Rolliner 3G per meter	44-60-40
Corrugated tube PUR black NW23 per meter	91-3-2
Connector wire inlet for Rolliner 3G	44-60-41
Wire drum connector for Rolliner NG	44-60-30

Option

Overview of strain-relief on wire guidance	Part-No.
Strain-relief wire guidance for Rolliner	14-10-8
Clamping Piece Rolliner 3G on Cable Bundle -A-	44-60-48

Please note:

Two connection sets are needed.

Alternative



Wire inlet bodies for additional systems

Beside the wire inlet body for the SKS wire guidance, inlet bodies for additional systems are available.

Overview of wire inlet bodies for additional systems	Part-No.
Wire inlet body for PF5/6 with M10 internal thread for ESAB	10-2-0-50
Wire inlet body for PF5/6 with 9.6 mm bore hole	10-2-0-52
Wire inlet body for PF5/6 with 13 mm bore hole	10-2-0-53
Wire inlet body for PF5/6 with PG9 thread	10-2-0-56
Wire inlet body for PF5/6 with internal thread 1/4" NPTF	10-2-0-60

6 Ground cable



Please note:

Further lengths and diameters available on request

Ground cable with 70 mm² connector and cable lug

The use of highly pure copper reduces the electric resistance supporting the welding process. Manufactured as of DIN VDE 0285-525-2-81 / DIN EN 50525-2-81.

Overview of ground cables	Part-No.
Ground cable 70 mm ² 6 m with DIX plug and cable lug	228078106
Ground cable 70 mm ² 10 m with DIX plug and cable lug	228078100

Option

Overview of ground cables	Part-No.
Ground cable 95 mm ² 6 m with DIX plug and cable lug	228080106
Ground cable 95 mm ² 10 m with DIX plug and cable lug	228080110

7 Control cable



Please note:

For the Frontpull 8 system three control cables are needed. One control cable is already included in the cable bundle.

Please note:

Further lengths available on request.

Control cable: L700/SPW-Bus

One cable to connect power source, weld process controller, interface and frontpull module. By use of one cable stock and installation is simplified. The power is supplied via this cable. An external supply is not necessary.

Overview of control cables	Part-No.
Control cable 0.5m L700/SPW-Bus	541031050
Control cable 1m L700/SPW-Bus	541031001
Control cable 2m L700/SPW-Bus	541031002
Control cable 3m L700/SPW-Bus	541031003
Control cable 5m L700/SPW-Bus	541031005
Control cable 7m L700/SPW-Bus	541031007
Control cable 10m L700/SPW-Bus	541031000
Control cable 12m L700/SPW-Bus	541031012
Control cable 15m L700/SPW-Bus	541031015

Plug & Play: Control cable L700

The advantages of a system concept are revealed by its details: One standard control cable (L700) connects all system components (power source, robot interface, weld process controller and wire feeder) within the welding system. The system is expandable: Other components can be integrated at any time into an existing system. New devices are automatically detected.

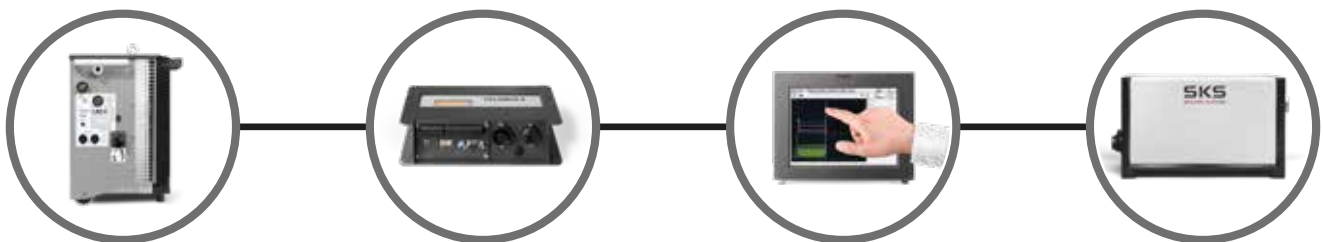

Power Source

Robot Interface

Weld Process Controller

Wire Feeder

8 Cable bundle



Cable bundles: Power source to PF6

Coaxial power cable 72 mm² with internal gas flow, control cable L700, disconnect cable, corrugated tube and cable holder. Air-cooled version.

Overview of cable bundles	Part-No.
Cable bundle 72mm ² 5m -A- LSQ-PF5/6	20-4-5
Cable bundle 72mm ² 7m -A- LSQ-PF5/6	20-4-7
Cable bundle 72mm ² 10m -A- LSQ-PF5/6	20-4-10

Alternative

Overview of cable bundles with air-blast function	Part-No.
Cable bundle 72mm ² 5m -A- LSQ-PF5/6 with air-blast function	20-19-5
Cable bundle 72mm ² 7m -A- LSQ-PF5/6 with air-blast function	20-19-7
Cable bundle 72mm ² 10m -A- LSQ-PF5/6 with air-blast function	20-19-10
Air blast valve for mounting on the wire feeder bracket	93-50

Please note:

Further lengths available on request.

8 Cable bundle: Clamping set

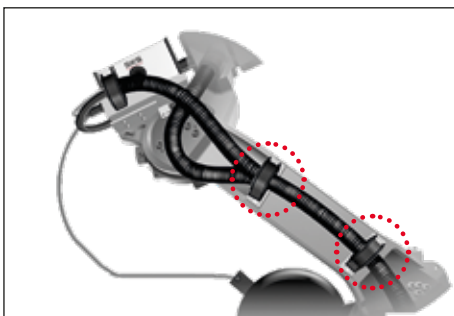

Mounting cable bundle: clamping set -A-

Provides perfect installation of the cable bundle for all different robot types. Undesired cable movements are prevented. This results in higher lifetime.

Overview of clamping sets	Part-No.	For robot type-KUKA
For robot type-ABB		
IRB 1600iD-4/1.5 / IRB 1660iD-6/1.55	91-3-0-41-10	KR 6 R1840-2 HW / KR 8 R1440-2 HW / KR 8 R1640-2 HW / KR 8 R2100-2 HW
IRB 2600iD-15/1.85 / IRB 2600iD-8/2.00	91-3-0-41-11	
For robot type-FANUC		For robot type-YASKAWA
AM 100iD / AM 120iD	91-3-0-41-23 (optional 91-3-0-41-30)	AR1440 / AR2010 / GP12 / GP25-12
M-10iD/8L / M-20iD/12L	91-3-0-41-23	91-3-0-41-22

Please note:

Clamping sets for further robot types are available on request.

Alternative

Mounting for WF-bracket	Part-No.
Mounting for WF-bracket for external guided cable bundle	14-10-10

8 Dividable cable bundles

Alternative



70 mm² Connection from power source to connection bracket -A-

Length	Part-No.	Part-No. (with air-blast function)
5 m	20-7-5	20-21-5
7 m	20-7-7	20-21-7
10 m	20-7-10	20-21-10

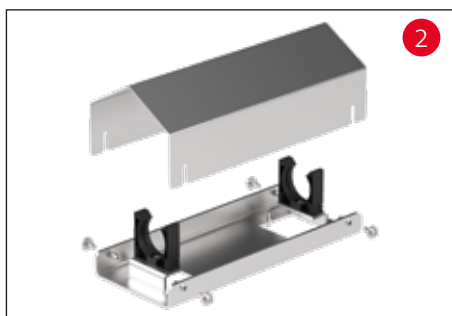

Connection bracket for cable bundles (PF6) -A-

	Part-No.
Connection bracket	20-6-0-3



Connection 72 mm² from connection bracket to PF6 -A-

Length	Part-No.	Part-No. (with air-blast function)
3 m	20-6-3	20-20-3
5 m	20-6-5	20-20-5
7 m	20-6-7	20-20-7

Please note:

Further lengths available on request.

Please note:

For use of the air blast function the air blast valve (Part-No. 93-50) is required.

Cable bundle with separation between power source and wire feeder PF6

The moving parts of the cable bundle (next to the robot) are separated from the non-moving parts (power source). In case of maintenance work, only the moving parts have to be changed. The quick and easy replacement concept results in time and cost savings.



9 Torch system Power Joint

The new freedom of motion.

Power Joint for hollow wrist robots with inner torch cable.



The Power Joint torch system perfects the interaction of welding machines and robots with inner cable dress. A single rotary joint, endlessly rotatable, transmits electrical energy and all media such as gas, air and wire. This reduces torch cable movement (no twisting/no torsional strain) and therefore increases the lifetime of the torch cable. The lack of reorientations also saves airtime because the torch reaches every position in the shortest possible path.

Power Joint – air-cooled for steel applications

Processes:	GMAW, KF-pulse, Pulse, MIG-Brazing
Wire materials:	high-alloy steels, low-alloy steels
Compatibility:	for all common industrial robots
Weight:	2.3 kg
Max. power:	420 A – 60 % duty cycle/40 °C, air-cooled
Wire diameter:	0.8-1.6 mm
TCP accuracy:	± 0.2 (400 mm)

9 Torch System Power Joint: Parts Overview

All parts of the Power Joint torch system at a glance.



- 9a Torch body Power Joint
- 9b Robot mounting
- 9c Torch cable and accessories
- 10a Torch Neck
- 10b Consumables
- 10c Gas Nozzle

9 Torch System Power Joint: Parts Overview

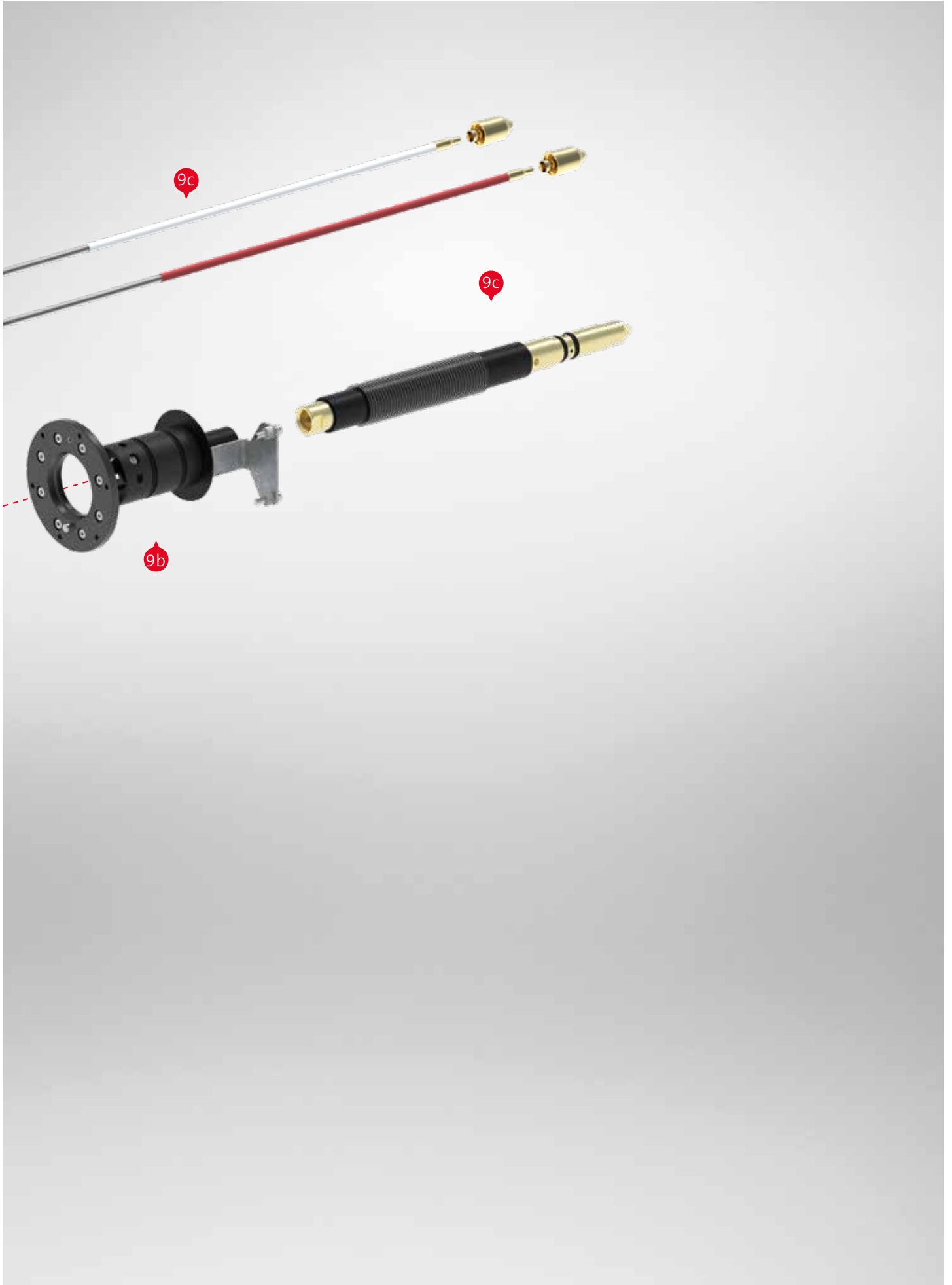

9a Torch system: Collision protection



Power Joint for all industrial robots with inner cable dress

A single rotary joint, endlessly rotatable, transmits electrical energy and all media such as gas, air and wire. This reduces torch cable movement (no twisting/no torsional strain) and therefore increases the lifetime of the cable. The lack of reorientations also saves airtime because the torch reaches every position in the shortest possible path.

Power Joint	Part-No.
Power Joint	71-9-0



Technical data Power Joint

Welding current	420 A - 60 % ED
Switch-Off automatic system	Deflection 10°
Reset accuracy	± 0.2 mm with TCP 400 mm
Weight	1.8 kg

9b Torch system: Robot mounting



Please note:

Mounting kits for further robot types available on request.

Mounting kit Power Joint

Overview of mounting kits	Part-No.
For robot type-ABB	
IRB 1600iD-4/1.5	71-9-0-3
IRB 1660iD-6/1.55 / IRB 2600iD-15/1.85 / IRB 2600iD-8/2.00	71-9-0-9
For robot type-FANUC	
AM 100iD / M10iD/8L / M-20iD/12L	71-9-0-19
AM 120iD	71-9-0-21
For robot type-KUKA	
KR 6 R1840-2 HW / KR 8 R1440-2 HW / KR 8 R1640-2 HW / KR 8 R2100-2 HW	71-9-0-17
For robot type-YASKAWA	
AR1440 / AR2010 / GP12 / GP25-12	71-9-0-16

9c Torch system: Torch cable and accessories



Please note:

Torch for other robot types are available on request..

Torch cable with inner cable dress

High flexible coaxial cable 72 mm² with air blast tube, disconnection cable and Power Pin

Overview of recommended torch cable lengths for robots	Part-No.
For robot type-ABB	
IRB 1600iD-4/1.5	61-9-1800
IRB 1660iD-6/1.55	61-9-100-6
IRB 2600iD-15/1.85	61-9-2600-15
IRB 2600iD-8/2.00	61-9-2600-8

For robot type-FANUC

AM 100iD	61-9-100
AM 120iD	61-9-120
M-10iD/8L	61-80-120-10
M-20iD/12L	61-9-M20iD-12L

For robot type-KUKA

KR 6 R1840-2 HW	61-9-MH24
KR 8 R1440-2 HW / KR 8 R1640-2 HW	61-9-1420
KR 8 R2100-2 HW	61-9-120

For robot type-YASKAWA

AR 1440 / GP 12	61-9-1440
AR 2010 / GP 25-12	61-9-2010



Liner

Overview liners	Part-No.
SKS Front Load Liner 2.3m, Wire-ø 0.8–1.0mm, Steel	44-34-10-2350-S
SKS Front Load Liner 3.5m, Wire-ø 0.8–1.0mm, Steel	44-34-10-3550-S
SKS Front Load Liner 2.3m, Wire-ø 1.2–1.6mm, Steel	44-34-16-2350-S
SKS Front Load Liner 3.5m, Wire-ø 1.2–1.6mm, Steel	44-34-16-3550-S
Power Pin Cap for SKS Front Load Liner	61-2-0-2-17

**INCLUDING
STOP'N'LOCK
FUNCTION**



The new SKS Front Load Liner

This new liner system will replace the current Quick Load liner system, providing the same installation features and product performance, along with a lower list price.



Torch necks for Power Joint

SKS torch necks are available in different geometries and for a wide range of applications. With its innovative bajonet lock system, the SKS torch neck can be replaced quickly. This unique tool-free quick change system is also highly precise with TCP accuracy of $\pm 0,2$ mm. Their design concept allows them to be used in areas where market standard torch necks would already require water cooling.

Overview of torch necks			Application recommendations	
Type	Part-No.	angle [°]	TCP length [mm]	steel/CrNi
standard dressing air-cooled	58-1-00-400-1	0	400.0	✓
	58-1-22-350-1	22	350.0	✓
	58-1-22-400-1	22	400.0	✓
	58-4-330-500-1	30	438.5	○
	58-1-130-450-1	30	450.0	○
	58-1-35-400-1	35	400.0	✓
	58-1-45-350-1	45	350.0	✓
	58-1-45-400-1	45	400.0	✓✓
	58-1-45-450-1	45	450.0	✓
	58-4-345-450-1	45	388.5	✓
	58-4-345-567-1	45	505.5	✓

Type	Part-No.	angle [°]	TCP length [mm]	steel/CrNi
ZK	58-1-245-400-1	45	400.0	✓

- ✓✓ Recommended standard torch neck
- ✓ Recommended
- Special design: To be checked for specific application

Please note:

For information about aluminum application please see our brochures "Frontpull 8 Aluminum".

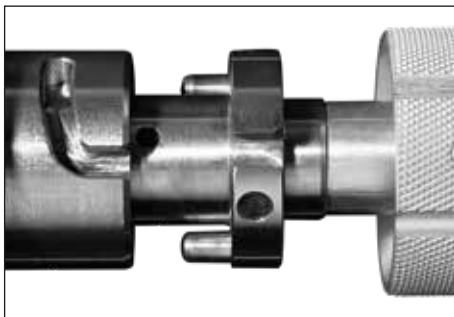

Info: Torch Neck

SKS offers a special torch neck (up to 250 A, ZK-HeavyDuty up to max. 300 A) for welding components with tight accessibility. The special torch neck needs a smaller insulator (ZK) and a more compact gas nozzle (ZK). Standard Power Lock contact tips can be used. TCP drawings can be found on the next to last page (torch necks).



Clamping cap for SKS single wire torch necks

Tool-free assembly with bajonet quick-change system

Clamping cap	Part-No.
Clamping cap	71-3-25



Isolator für SKS Brennerhalse

Overview of insulators	Part-No.
Torch neck insulator	58-1-5
Torch neck insulator ZK-HD	43-6-4-3

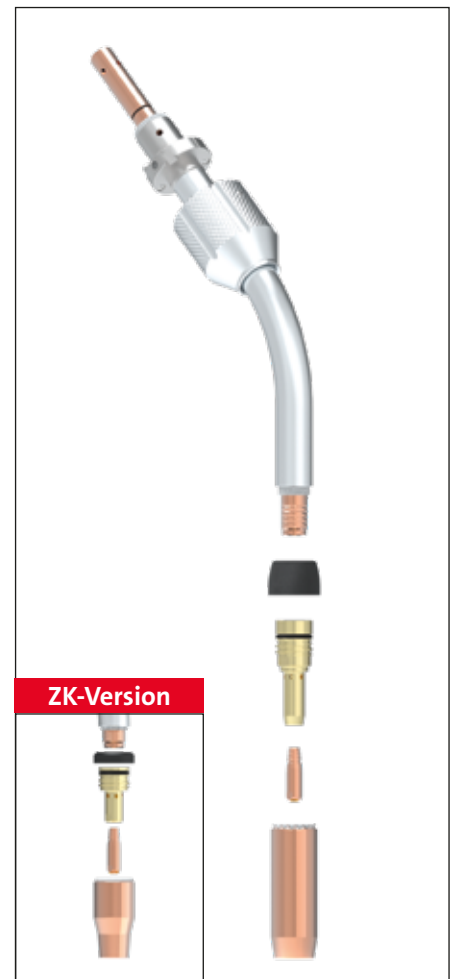

10a Torch necks

Torch neck change with the SKS bayonet locking concept



Find an interactive animation of how it works in the QR code



Please note:

Animation using the example of a standard torch neck in the Power Joint Weld Package.

10b Consumables



Power Lock Plus: retaining head

Heavy duty retaining head with thread for threaded gas nozzles for simple and safe installation

Overview of retaining heads	Part-No.
Heavy duty retaining head Power Lock Plus (6 holes)	43-16-6
Heavy duty retaining head Power Lock Plus - ZK (6 holes)	43-24-1

Please note:

An overview with dimensions can be found on the page after next.

10b Consumables



Please note:

Contact tips for wires in inch sizes available on request.

Power Lock Plus: Contact tip

- Tapered design for high TCP reproducibility
- Improved heat transfer extends lifetime
- Improved power transition: constant arc quality

Overview of contact tips	Part-No.
Contact tip Power Lock Plus for wire- ϕ 0.8 mm, E-Cu	40-6-5-0.8E
Contact tip Power Lock Plus for wire- ϕ 0.9 mm, E-Cu	40-6-5-0.9E
Contact tip Power Lock Plus for wire- ϕ 1.0 mm, E-Cu	40-6-5-1.0E
Contact tip Power Lock Plus for wire- ϕ 1.2 mm, E-Cu	40-6-5-1.2E
Contact tip Power Lock Plus for wire- ϕ 0.8 mm, HD-CuCrZr	40-6-7-0.8S
Contact tip Power Lock Plus for wire- ϕ 0.9 mm, HD-CuCrZr	40-6-7-0.9S
Contact tip Power Lock Plus for wire- ϕ 1.0 mm, HD-CuCrZr	40-6-7-1.0S
Contact tip Power Lock Plus for wire- ϕ 1.2 mm, HD-CuCrZr	40-6-7-1.2S
Contact tip Power Lock Plus for wire- ϕ 1.4 mm, HD-CuCrZr	40-6-7-1.4S
Contact tip Power Lock Plus for wire- ϕ 1.6 mm, HD-CuCrZr	40-6-7-1.6S

10c Gas nozzle



Please note:

An overview with dimensions can be found on the next page.

Please note:

Further information can be found in our brochure "Consumables" (DOC-0135EN).

Gas nozzles with thread

Standard gas nozzles	Part-No.
13 mm bottle shaped	
short	41-19-13-BS
flush	41-19-13-BF
long	41-19-13-BR
13 mm tapered	
short	41-19-13-TS
flush	41-19-13-TF
long	41-19-13-TR
15 mm bottle shaped	
short	41-19-15-BS
flush	41-19-15-BF
long	41-19-15-BR
16 mm tapered	
short	41-19-16-TS
flush	41-19-16-TF
long	41-19-16-TR

Heavy Duty gas nozzles	Part-No.
13 mm	
flush, bottle shaped	41-20-13-BF
long, tapered	41-20-13-TR
16 mm tapered	
kurz	41-20-16-TS
flush	41-20-16-TF
long	41-20-16-TR

ZK type gas nozzles	Part-No.
13 mm bottle shaped	
short	41-21-13-BS
flush	41-21-13-BF
15 mm bottle shaped	
short	41-21-15-BS
flush	41-21-15-BF
13+15 mm Heavy Duty/tapered	
13 mm flush	41-22-13-TF
15 mm flush	41-22-15-TF



Tools and accessories

For replacement of contact tips: Fast exchange of contact tip without removing the gas nozzle

Overview of tools and accessories	Part-No.
Mounting tool SW7 for contact tip (Power Lock Plus)	51-9002-00
Stopper-Key for drive rolls (Std & Lite)	93-100-3-3
SKS Multitool for single wire torch systems	47-11



Programming tips

Programming tips for precise seam programming

Overview of programming tips	Part-No.
Stickout	
10 mm (Power Lock Plus)	65-17
12 mm (Power Lock Plus)	65-11
15 mm (Power Lock Plus)	65-12
18 mm (Power Lock Plus)	65-24

10c Gas nozzles: Overview dimensions

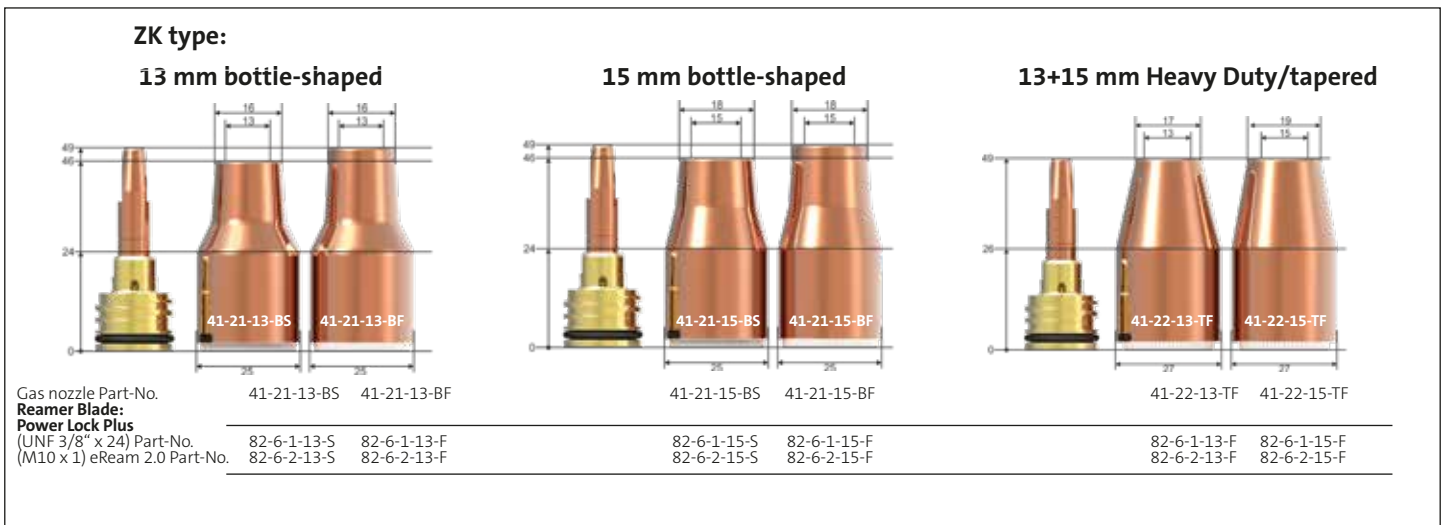
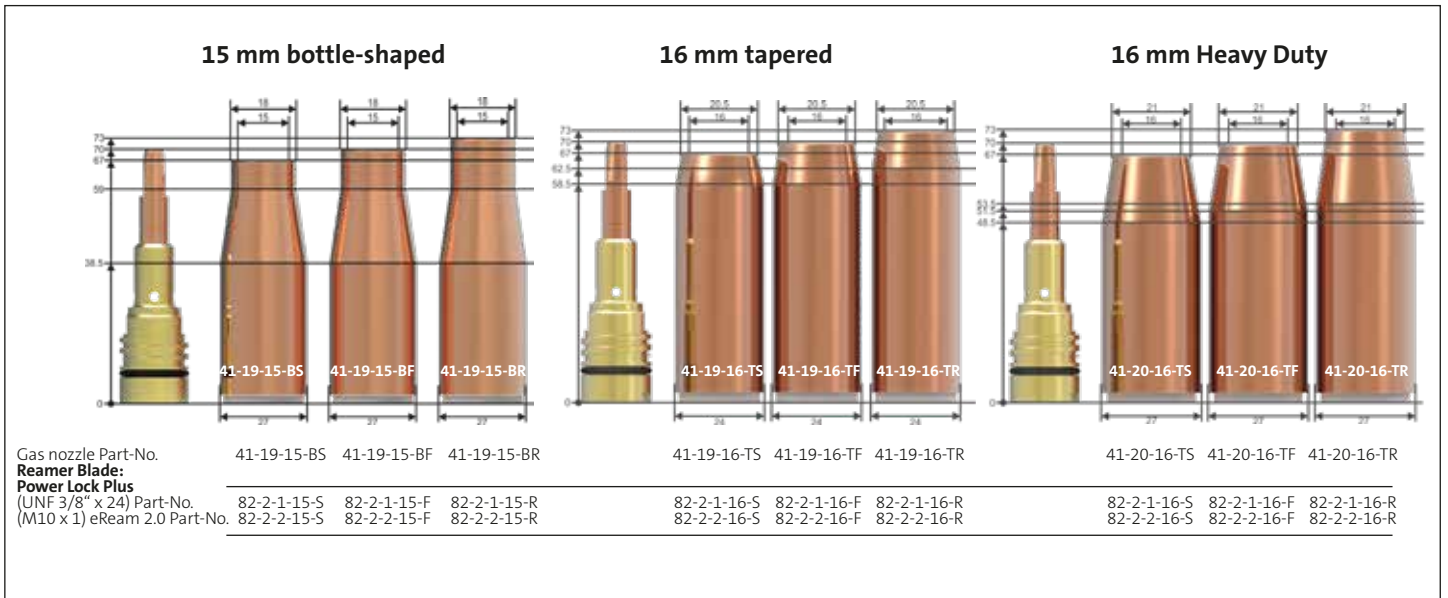
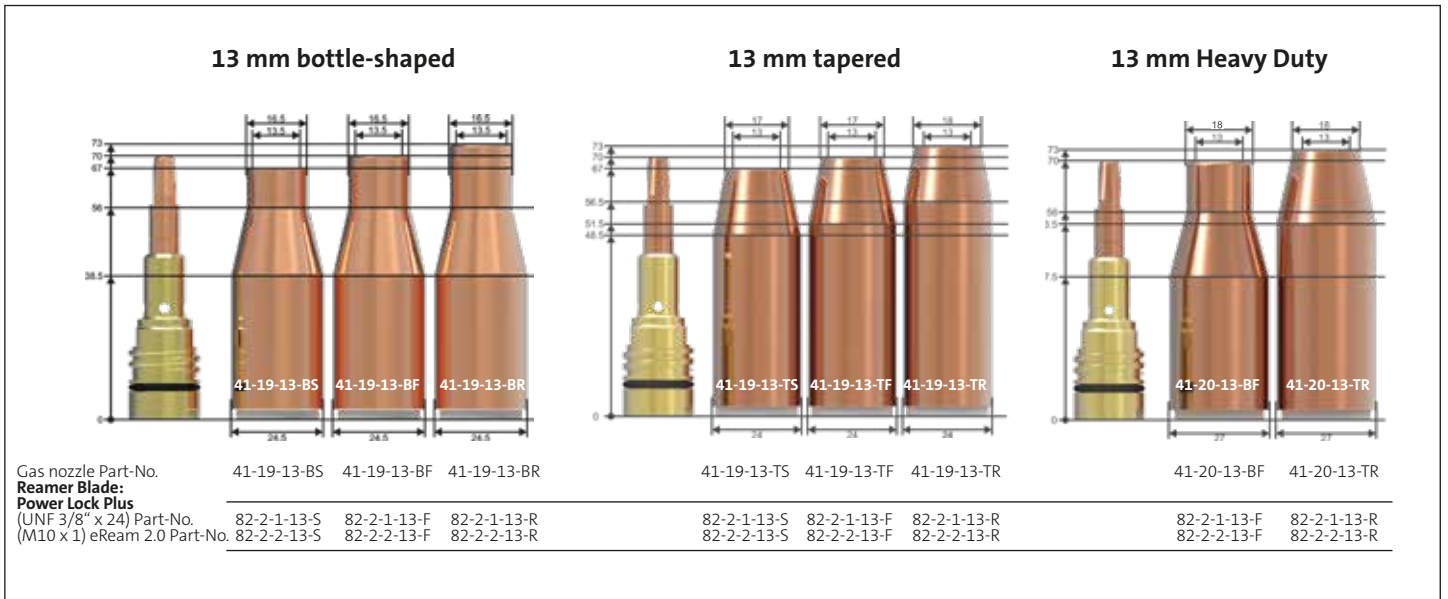

Please note:

Further gas nozzles, reamer blades and torch necks can be found in our consumables brochure.

Please note:

Dimensions in mm.

11 Reamer blades

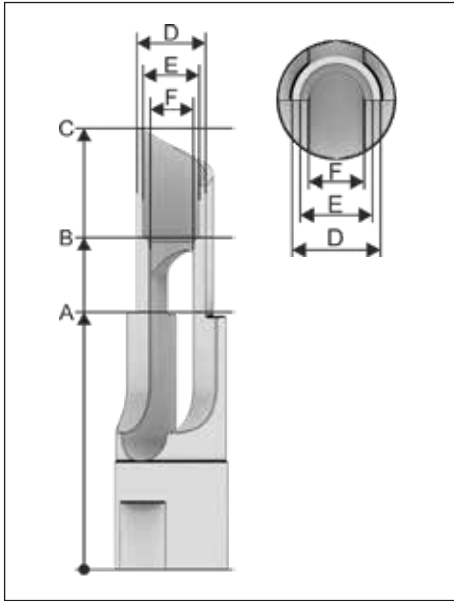

Reamer blade (internal thread UNF 3/8" x 24)

For pReam cleaning station

Overview of reamer blades	Part-No.	Part-No.	Part-No.
Inner diameter of the gas nozzle	short	flush	long
13 mm	82-2-1-13-S	82-2-1-13-F	82-2-1-13-R
15 mm	82-2-1-15-S	82-2-1-15-F	82-2-1-15-R
16 mm	82-2-1-16-S	82-2-1-16-F	82-2-1-16-R

Dimensions						Part-No.
A	B	C	D	E	F	
13 mm inner diameter						
55.5	-	67	12.5	9	-	82-2-1-13-S
52.5	-	67	12.5	9	-	82-2-1-13-F
49.5	-	67	12.5	9	-	82-2-1-13-R
15 mm inner diameter						
51	63	91	14.5	11.8	9	82-2-1-15-S
48	63	91	14.5	11.8	9	82-2-1-15-F
45	63	91	14.5	11.8	9	82-2-1-15-R
16 mm inner diameter						
51	63	91	15.5	11.8	9	82-2-1-16-S
48	63	91	15.5	11.8	9	82-2-1-16-F
45	63	91	15.5	11.8	9	82-2-1-16-R

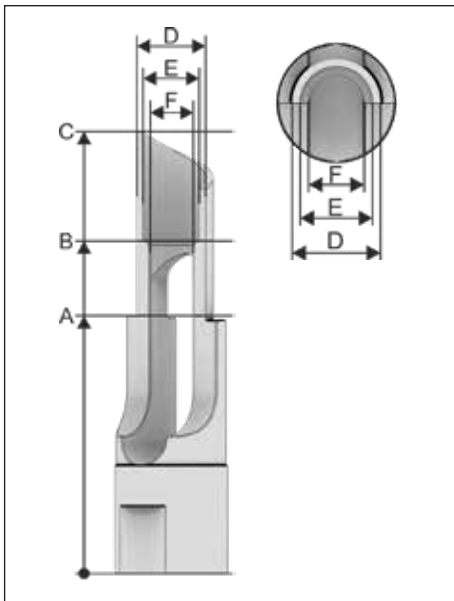

Reamer blade (internal thread M10 x 1)

For eReam 2.0 cleaning station

Overview of reamer blades	Part-No.	Part-No.	Part-No.
Inner diameter of the gas nozzle	short	flush	long
13 mm	82-2-2-13-S	82-2-2-13-F	82-2-2-13-R
15 mm	82-2-2-15-S	82-2-2-15-F	82-2-2-15-R
16 mm	82-2-2-16-S	82-2-2-16-F	82-2-2-16-R

Dimensions						Part-No.
A	B	C	D	E	F	
13 mm inner diameter						
66.5	-	78	12.5	9	-	82-2-2-13-S
66.5	-	81	12.5	9	-	82-2-2-13-F
66.5	-	84	12.5	9	-	82-2-2-13-R
15 mm inner diameter						
38	50	78	14.5	11.8	9	82-2-2-15-S
38	53	81	14.5	11.8	9	82-2-2-15-F
38	56	84	14.5	11.8	9	82-2-2-15-R
16 mm inner diameter						
38	50	78	15.5	11.8	9	82-2-2-16-S
38	53	81	15.5	11.8	9	82-2-2-16-F
38	56	84	15.5	11.8	9	82-2-2-16-R

Please note:

Dimensions in mm.

11 Reamer blades: ZK type

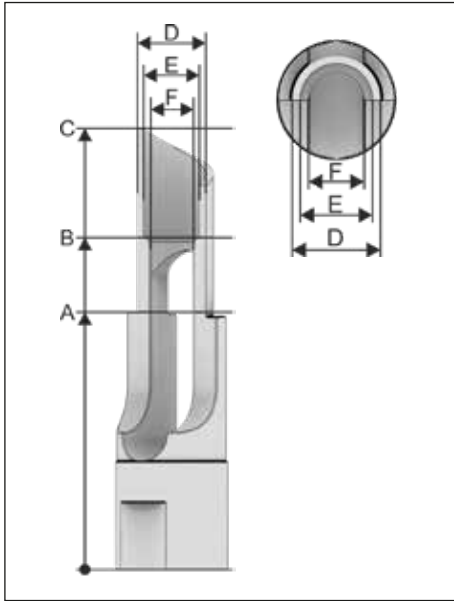

Reamer blade ZK series Power Lock Plus (internal thread UNF 3/8" x 24)

For pReam cleaning station

Overview of reamer blades	Part-No.	Part-No.	Part-No.
Inner diameter of the gas nozzle	short	flush	long
13 mm	82-6-1-13-S	82-6-1-13-F	-
15 mm	82-6-1-15-S	82-6-1-15-F	-

Dimensions						Part-No.
A	B	C	D	E	F	
13 mm inner diameter						
45	-	77	12.5	11.8	9	82-6-1-13-S
42	-	77	12.5	11.8	9	82-6-1-13-F
15 mm inner diameter						
45	-	77	14.5	11.8	9	82-6-1-15-S
42	-	77	14.5	11.8	9	82-6-1-15-F

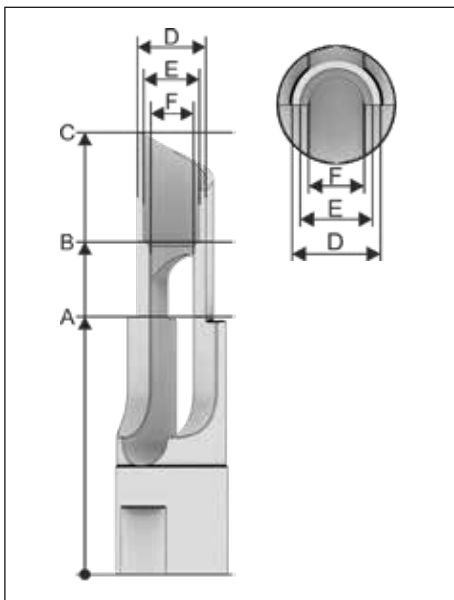

Reamer blade ZK series Power Lock Plus (internal thread M10 x 1)

For eReam 2.0 cleaning station

Overview of reamer blades	Part-No.	Part-No.	Part-No.
Inner diameter of the gas nozzle	short	flush	long
13 mm	82-6-2-13-S	82-6-2-13-F	-
15 mm	82-6-2-15-S	82-6-2-15-F	-

Dimensions						Part-No.
A	B	C	D	E	F	
13 mm inner diameter						
45	-	77	12.5	11.8	9	82-6-2-13-S
42	-	77	12.5	11.8	9	82-6-2-13-F
15 mm inner diameter						
45	-	77	14.5	11.8	9	82-6-2-15-S
42	-	77	14.5	11.8	9	82-6-2-15-F

Please note:

Dimensions in mm.

12 TCP dimensions

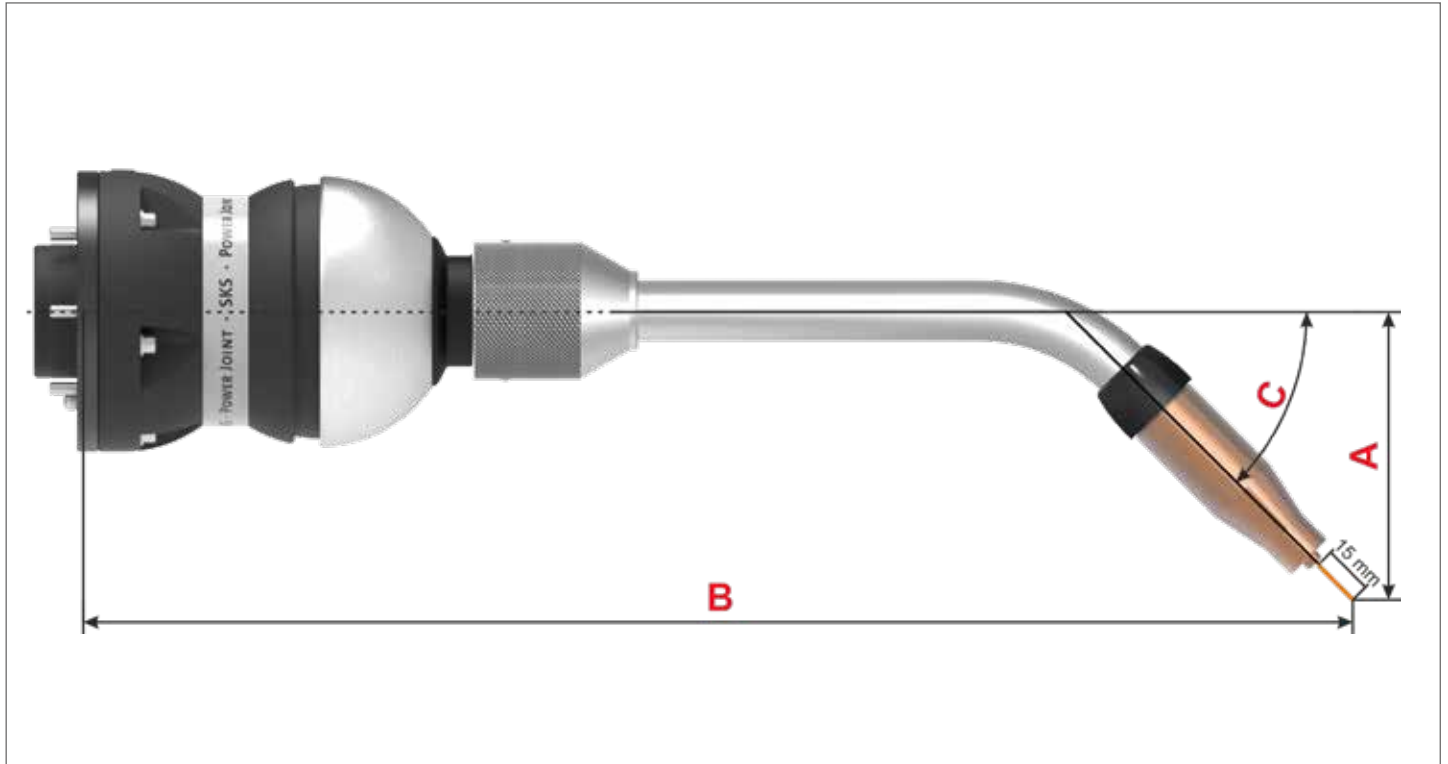

Overview of standard torch necks air-cooled

standard dressing	A	B	C
Part-No.	(distance in mm)	(TCP length in mm)	(angle in °)
58-1-00-400-1	0	400.0	0
58-1-22-350-1	45	350.0	22
58-1-22-400-1	45	400.0	22
58-4-330-500-1	120	438.5	30
58-1-130-450-1	0	450.0	30
58-1-35-400-1	70	400.0	35
58-1-45-350-1	90	350.0	45
58-1-45-400-1	90	400.0	45
58-1-45-450-1	90	450.0	45
58-4-345-450-1	120	388.5	45
58-4-345-567-1	120	505.5	45

Overview ZK type torch necks

standard dressing	A	B	C
Part-No.	(distance in mm)	(TCP length in mm)	(angle in °)
58-1-245-400-1	62	400,0	45

Please note:

Dimensions in mm.

12 Checking fixtures

Checking fixtures

To check TCP of torch necks and complete torch.

Checking fixtures are provided for all listed torch necks with Power Joint torch system. Please contact us for detailed information.

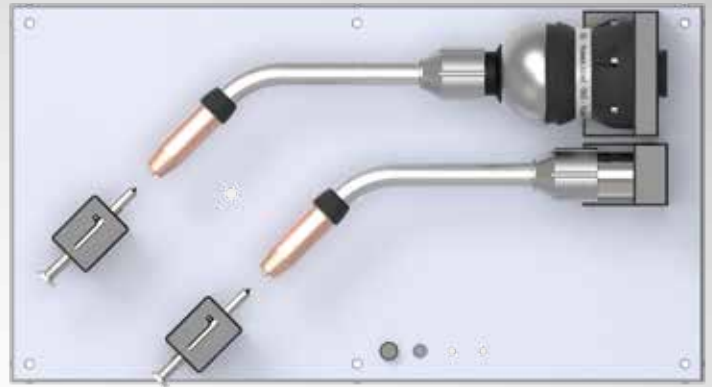

Top view checking fixture



Please note:

Further information can be found in our brochure "Checking fixtures" (DOC-0137EN).

12 Torch cleaning stations

eReam 2.0 for
a precise cleaning of
the torch frontend

For further information
please scan this QR code:



Pure
Electric.

Please note:

Further information can be found in our eReam 2.0 brochure (DOC-0205EN).

pReam: pneumatic
cleaning station

Further information can
be found here:



Power Joint water-cooled:

Endless rotation
with water cooling



Further information about the Power Joint
water-cooled Weld Package can be found here:



Please note:

Further information can be found on our website at
www.sks-welding.com/en/products/torch-systems

SKS

WELDING SYSTEMS



Contact:
[sales@
 de.sks-welding.com](mailto:sales@de.sks-welding.com)

SKS Welding Systems GmbH

Marie-Curie-Str. 14 | 67661 Kaiserslautern | Germany | Phone +49 6301 7986-0

www.sks-welding.com

 /sksweldingsystems

 /DesignTechnologyPerformance

 @sks_welding_systems

 /sks-welding-systems